

2025

GENERAL CATALOGUE



MEGA



PICTOGRAMS OF OUR SAFETY FEATURES



Safety overload valve.
It prevents the jack from exceeding its nominal capacity.



Hydraulic stroke limiter.
Hydraulic limit switch that limits excess piston travel in order to prevent its damage.



Operation by the "Deadman" principle
(stops operation if the user loses control accidentally).



Lowering Control System Device (LCS).
It acts automatically providing a smooth, even and safe descent of the load, in any circumstances, even if it is due to a sudden and/or accidental opening of the discharge.



Automatic spring return piston.



Manometer.



Extendable screw for fast and precise approach.



Visit the corporate video
on our Youtube channel



Presentation

1 Our Essence

At **MEGA**, we have been manufacturing hydraulic lifting solutions since 1940. Our passion for engineering and commitment to quality have made us an international benchmark. From our beginnings in the Basque Country, we have grown to be present in over 100 countries, without ever losing our spirit of continuous improvement.

2 What Sets Us Apart

Full in-house manufacturing, which allows us complete control over every stage of the process. We stand out by offering uncompromising quality, using top-grade materials and certified processes. We focus on applied innovation, prioritizing safety, ergonomics, and efficiency. We also work closely with international brands through OEM and ODM partnerships.

3 Our Product Range

We design and manufacture equipment for the automotive and industrial sectors.

Hydraulic jacks, presses, cranes, cylinders, pumps, and mobile solutions are part of our portfolio, all adapted to demanding environments. We offer heavy-duty professional equipment and custom-made solutions under private label.



4 Technology at the Service of the User

We incorporate technologies that make a difference: active safety systems such as the "dead man system" mechanism or hydraulic stroke limiters that prevent overloads.

We design using cutting-edge tools and structural simulations to ensure robustness and precision.

5 Commitment to Excellence

We carry out rigorous testing for load, pressure, and durability. Each unit has full traceability from origin, ensuring reliability and serviceability. Our products are designed for a long service life and can be easily serviced and maintained, even under the most demanding conditions.

6 A Global Network

We have a consolidated network of distributors across five continents. Our strong production capacity ensures fast deliveries, and our technical team provides expert support. We guarantee spare parts availability and technical assistance to keep our products operational for years.

7 Looking Ahead

Hydraulics is not just our field, it's our passion. At **MEGA**, we continue to invest in technology, sustainability, and talent to offer safer, smarter, and more durable solutions.

MEGA 

85 years building trust.

MEGA



The brand

The prestige of a brand cannot be improvised

With more than 80 years of history, at **MEGA**, we base our reputation on a tradition of quality, credibility and know-how, which is renewed every day, and enriched by generations of professionals committed to surpassing the high quality of our tools and guaranteeing a promising future for the **MEGA** brand.

International

Our equipment is a daily help in the most demanding workshops around the world. A strong commitment to service, a long and solid export history and a serious, transparent and carefully chosen distribution policy, are the keys that explain our recognition and international expansion.

Sector leader

We are committed to a sustained and controllable expansion, a balanced growth that does not compromise our quality or the exclusivity of our offer.

Faced with the temptation of diversification, we are selective. We aim to collaborate with prestigious distributors who share our values and protect our reputation, in an exercise of mutual reinforcement and fair reciprocity.

| | |
|--|----|
| Trolley jacks..... | 6 |
| Heavy duty trolley jacks..... | 9 |
| Air hydraulic jacks..... | 11 |
| Air hydraulic bottle jacks..... | 14 |
| Bottle jacks..... | 15 |
| Cranes..... | 18 |
| High lift transmission jacks..... | 21 |
| Presses..... | 22 |
| Lifting tables..... | 33 |
| Pneumatic table for motorcycles..... | 33 |
| Wheel dolly..... | 34 |
| Transmission jack..... | 35 |
| Body repair kits..... | 36 |
| Body aligning set..... | 37 |
| Pneumatic Jack..... | 38 |
| Single-acting pedal-operated oil-pneumatic pump..... | 38 |
| Hydraulic pipe benders..... | 39 |
| Axle stands..... | 39 |
| Jack exhibitor..... | 40 |
| Index of references..... | 41 |



AVAILABLE
IN GREY

Trolley jacks GT

Main characteristics:

- **Safety system**, operation by the dead man's principle, stopping the operation if the user accidentally loses control.
- **New metal pedal**. Equipped with a fast approach pedal, fewer pumps, reduces effort and time.
- **Wider width between the rear wheels**, providing greater load stability and easy jacking.
- **Reinforced structure**, double sheet welded in high resistance steel.
- **Bigger wheels**, offer better stability on uneven ground. Made of polyamide for a lower noise level.
- **Tool tray integrated in chassis**.
- **Oversized support platform** with rubber pad, offers greater contact with the load.



Operation by "dead man's" principle.



Hydraulic stroke limiter.



Safety overload valve.



LCS lowering control system.



**NEW
PRODUCT**



Maximum height
785 mm

HIGH-LIFT JACK



Larger width between wheels. High load stability.



YouTube



Rubber pad included.

GT1.5H

1,5t jack designed for lifting cars and vans.
Maximum height 785 mm.



Adjustable platform
A-PF350

GT2

2t jack designed for lifting cars and vans.

Minimum height
95 mm



YouTube

| Model | Weight (kg) | Capacity (t) | A | B | C | D | E | F | G | H |
|---------------|-------------|--------------|-----|-----|-----|-------|-------|-------|-----|-----|
| GT1.5H | 62 | 1.5 | 110 | 170 | 785 | 1,315 | 1,250 | 2,040 | 360 | 277 |
| GT2 | 35 | 2 | 95 | 135 | 470 | 850 | 900 | 1,610 | 360 | 257 |

Measurements in mm.

NEW



Yellow pedal for unlocking the system



AVAILABLE IN GREY

THE SAFEST JACK ON THE MARKET DOUBLE SAFETY SYSTEM

GT2S

2t jack equipped with mechanical lowering lock. Exclusive safety system that prevents accidental lowering of the load by locking it at 320mm from the floor.

Minimum height
95 mm



GT2X

Ultra Low-profile jack, specially designed for lifting sport vehicles or reduced height.

Minimum height
70 mm



EXTRA LOW PROFILE



A-PF350

Transforms any MEGA GT trolley jack into a transmission jack or auxiliary platform using the new A-PF350 accessory, which allows you to easily add the adjustable PF350 platform to the jack.



| Model | Weight (kg) | Capacity (t) | A | B | C | D | E | F | G | H |
|-------|-------------|--------------|----|-----|-----|-----|-----|-------|-----|-----|
| GT2S | 37.5 | 2 | 95 | 135 | 470 | 850 | 900 | 1,610 | 360 | 257 |
| GT2X | 39.0 | 2 | 70 | 135 | 450 | 850 | 900 | 1,640 | 360 | 253 |

Measurements in mm.

Trolley jacks GT



AVAILABLE
IN GREY



GT3

3t jack designed for lifting cars and vans.

Minimum height
95 mm



Mechanical
safety lock system

**THE SAFEST JACK ON THE MARKET
DOUBLE SAFETY SYSTEM**

GT3S

3-ton jack equipped with mechanical locking during lowering. Exclusive safety system that prevents accidental drop by locking the load at 320 mm.

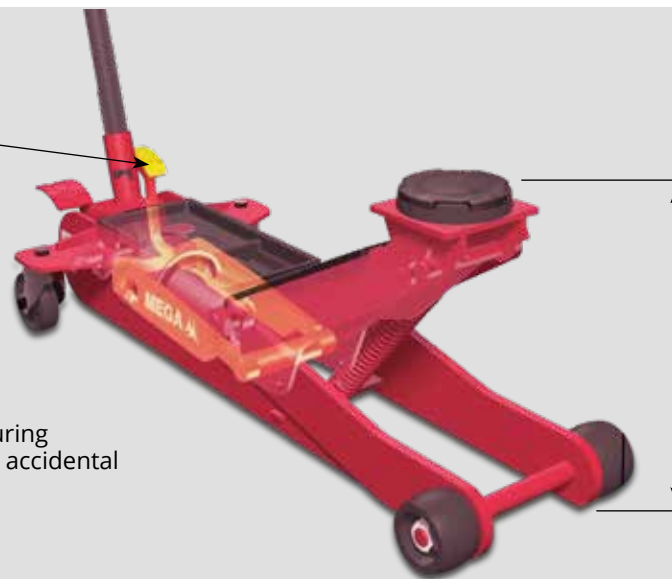

**NEW
PRODUCT**

System lock
320 mm

GT4

4t jack specially designed for lifting commercial vehicles, SUVs and off-road vehicles.



Minimum height
140 mm

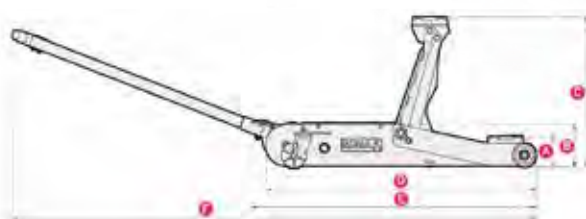

| Model | Weight (kg) | Capacity (t) | A | B | C | D | E | F | G | H |
|-------------|-------------|--------------|-----|-----|-----|-------|-------|-------|-----|-----|
| GT3 | 36.0 | 3 | 95 | 135 | 470 | 850 | 900 | 1,650 | 360 | 257 |
| GT3S | 40.0 | 3 | 95 | 135 | 470 | 850 | 900 | 1,610 | 360 | 257 |
| GT4 | 48.5 | 4 | 140 | 192 | 530 | 1,075 | 1,125 | 1,910 | 360 | 260 |

Measurements in mm.

NEW



Heavy duty trolley jacks T



AVAILABLE
IN GREY

- Suitable for all types of vehicles, from cars to industrial vehicles.
- Essential in truck fleets, bus company garages and agricultural machinery maintenance garages.
- Heaviest models have big wheels located in the centre of the chassis for better handling.
- Optimum use and distribution of material thanks to the rear side openings and front side reinforcements.



Operation by "dead man's" principle.



Hydraulic stroke limiter.



Safety overload valve.



LCS lowering control system.



T6 model handle.



T6



T10



Handle of models T10, T15 and T20.

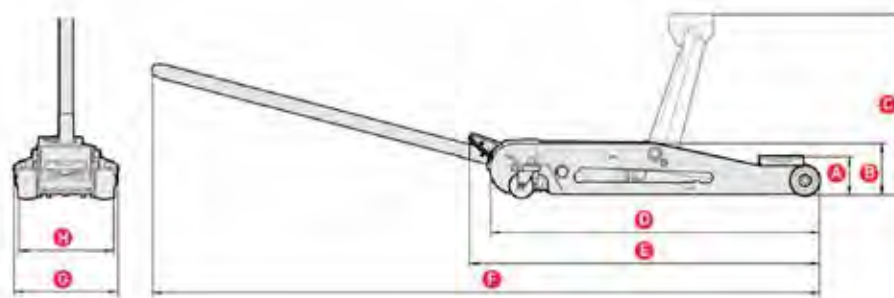

| Model | Weight (kg) | Capacity (t) | A | B | C | D | E | F | G | H |
|-------|-------------|--------------|-----|-----|-----|-------|-------|-------|-----|-----|
| T6 | 81.0 | 6 | 170 | 220 | 580 | 1,250 | 1,310 | 2,215 | 414 | 336 |
| T10 | 120.5 | 10 | 170 | 270 | 605 | 1,535 | 1,600 | 2,530 | 414 | 386 |

Measurements in mm.



AVAILABLE
IN GREY



Handle of models **T10**,
T15 and **T20**.

Quick approach
to the load pedal

T15

Steel wheels

T20

Steel wheels

Heavy duty trolley jacks **T**

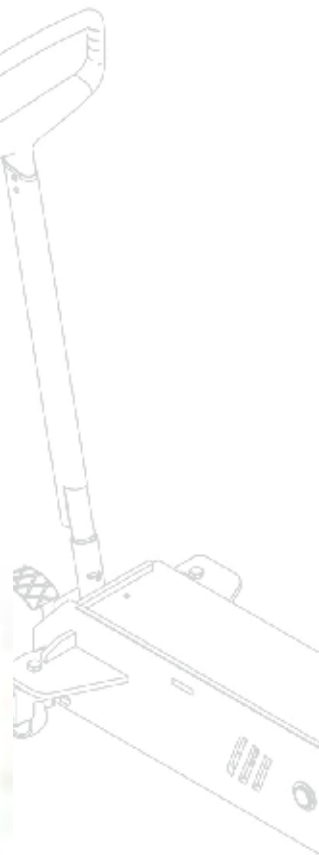
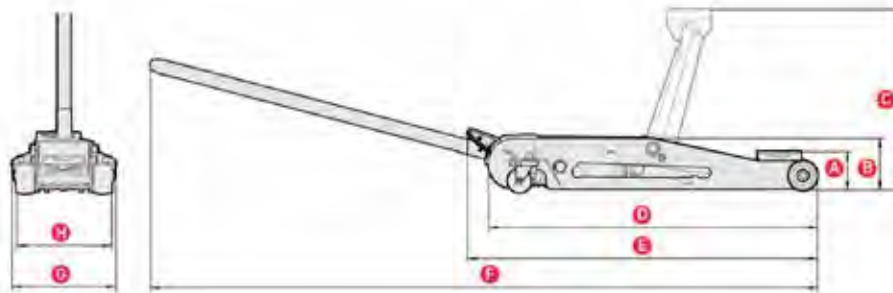

| Model | Weight (kg) | Capacity (t) | A | B | C | D | E | F | G | H |
|------------|-------------|--------------|-----|-----|-----|-------|-------|-------|-----|-----|
| T15 | 145.0 | 15 | 195 | 265 | 600 | 1,575 | 1,750 | 2,680 | 375 | 255 |
| T20 | 234.5 | 20 | 200 | 310 | 615 | 1,585 | 1,777 | 2,707 | 415 | 302 |

Measurements in mm.



AVAILABLE
IN GREY

Air hydraulic jacks for heavy vehicles N

- Specially designed to work on heavy vehicles, assistance, tyre and bodywork workshops.
- Highest quality steel. Their chrome molybdenum vanadium composition, strengthened by an anti-corrosion and anti-seize treatment through salt bath nitriding provides the jacks unbeatable resistance and durability properties.
- Modular concept. The independent modular construction design - lifting block, valve unit, pump motor, release cylinder and tank, simplifies assembly and makes maintenance easier.
- High approach speed and efficient load lifting.
- It holds the load up even if the air supply is interrupted.
- Recommended working pressure between **6 and 8 bars**.



Operation by "dead man's" principle.



Hydraulic stroke limiter.



Safety overload valve.



LCS lowering control system.



Single control switch.
Handy and easy to use.

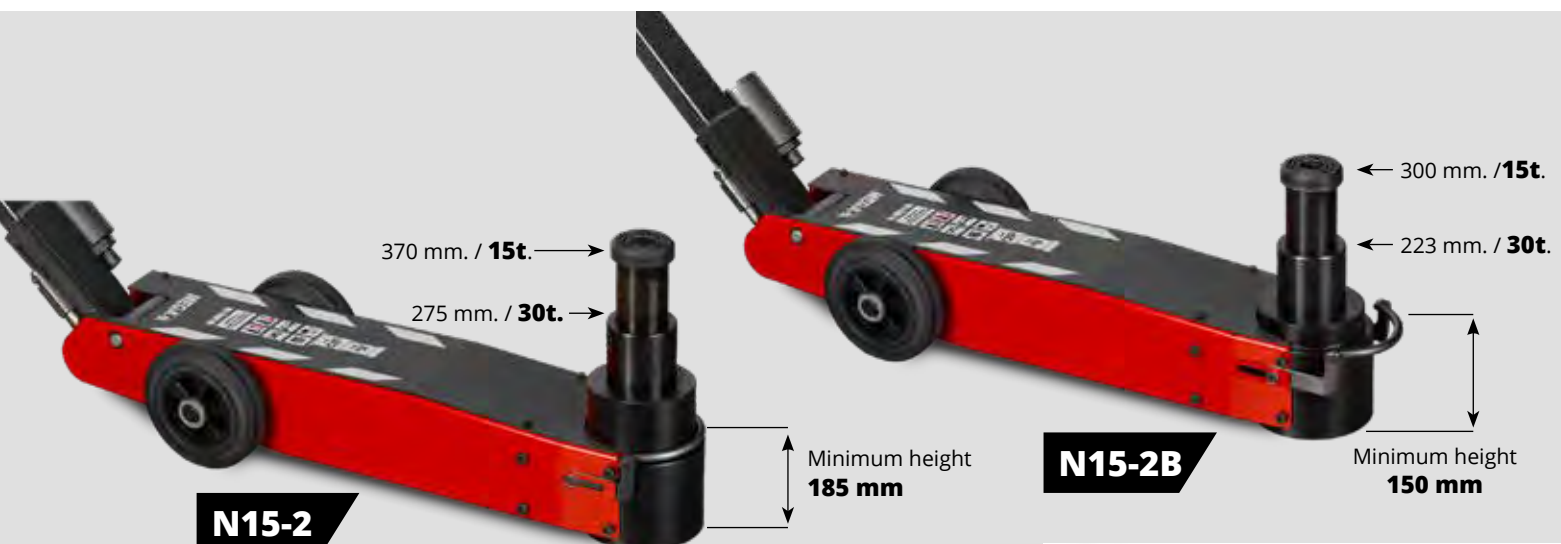

You
Tube

Look at the instructions
on our Youtube channel

See optional accessories on page 13

| Model | Weight (kg) | Capacity (t) | A | B | C | D | E |
|---------------|-------------|-----------------|-----|-----|-----|-----|-----|
| N10-3 | 41.0 | 10-20-35 | 807 | 160 | 345 | 157 | 260 |
| N15-2 | 46.5 | 15-30 | 807 | 185 | 470 | 157 | 280 |
| N15-2B | 43.5 | 15-30 | 807 | 150 | 400 | 157 | 280 |

Measurements in mm.

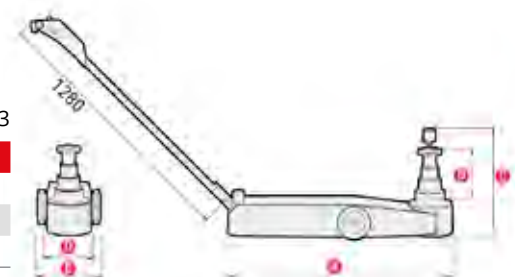



AVAILABLE
IN GREY



N15-4



Air hydraulic jacks for heavy vehicles **N**



N20-3



Single control switch.
Handy and easy to use.



Rotating handle on models that,
due to their size and weight, can
be transported by hand.



N25



Look at the instructions
on our Youtube channel

See optional accessories on page 13

| Model | Weight (kg) | Capacity (t) | A | B | C | D | E |
|--------------|-------------|--------------|-----|-----|-----|-----|-----|
| N15-4 | 70.5 | 15-30-50-80 | 810 | 235 | 490 | 212 | 317 |
| N20-3 | 69.5 | 20-35-65 | 793 | 235 | 515 | 194 | 317 |
| N25 | 47.0 | 25 | 560 | 108 | 423 | 157 | 280 |

Measurements in mm.

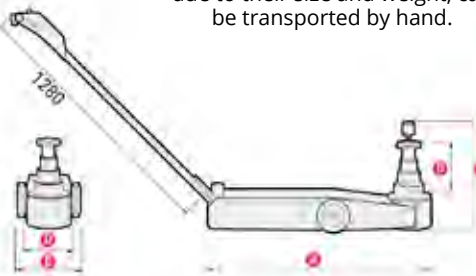



AVAILABLE
IN GREY

Portable air hydraulic jack NP

- Compact and lightweight design makes it perfect for heavy-duty roadside assistance.
- Reduced chassis width for positioning under the lifting point in areas of difficult access.
- It can be used with the vehicle's own compressor and be carried on board thanks to its small size (it may lift the nominal the nominal load with the extra extension).

Operation by "dead man's" principle.

Hydraulic stroke limiter.

Safety overload valve.

LCS lowering control system.



Handle in working position.

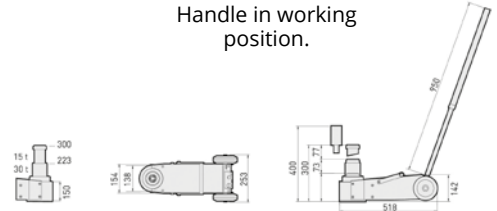

NP15-2B

The telescopic handle locks in three positions: **A** and **B**, for transport and **C**, position for working.



YouTube

| Model | Capacity (t) | Weight (kg) |
|----------------|--------------|-------------|
| NP15-2B | 15-30 | 31 |

Measurements in mm.

Accessories included

A-5211



L= 60 mm.

N10-3

A-5212



L= 100 mm.

N15-2B • N15-2 • NP15-2B • N15-4 • N20-3 • N25

Optional accessories

A-5205



L= 100 mm.

N10-3

A-5206



L= 50 mm.

N15-2B • N15-2 • N15-4 • N20-3 • N25





AVAILABLE
IN GREY

Air hydraulic bottle jacks BRB

They are very compact models. Their monobloc -integrated tank- and welded construction reduces their dimensions and makes transportation easier.

All models have an extension screw for a fast load approach, a high-performance remote-operated air pump and a salt bath nitriding hardened piston that ensures a long working life.



Operation by "dead man's" principle.



Hydraulic stroke limiter.



Safety overload valve.



LCS lowering control system.



BRB 20

Includes a rotating carrying handle



Swivel lever accessible from any position



| Model | Weight (kg) | Capacity (t) | Air pressure | Necessary air flow | A | B | C | D |
|--------------|-------------|--------------|-----------------|---------------------|-----|-----|----|-----|
| BRB20 | 15.5 | 20 | 7 bar / 100 psi | 270 l/min / 9.5 clm | 234 | 138 | 75 | 447 |
| BRB30 | 20.0 | 30 | 7 bar / 100 psi | 270 l/min / 9.5 clm | 242 | 138 | 75 | 455 |

Measurements in mm.





AVAILABLE
IN GREY

Bottle jacks 3 – 10 t BR

- Equipped with a unique rotatory pump socket system which can be operated from any position.
- All models have an extension screw for fast load approach.
- The base and bottle body are welded, providing greater durability, stability and safety in use.
- Telescopic zinc-plated handle, easy to store. Adequate length to ensure moderate pumping effort.



Safety overload valve.



Hydraulic stroke limiter.



BR3



Extension screw
for longer travel

BR5

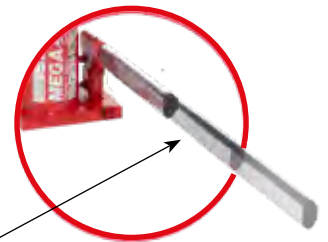

Zinc-plated
telescopic handle



BR10



YouTube

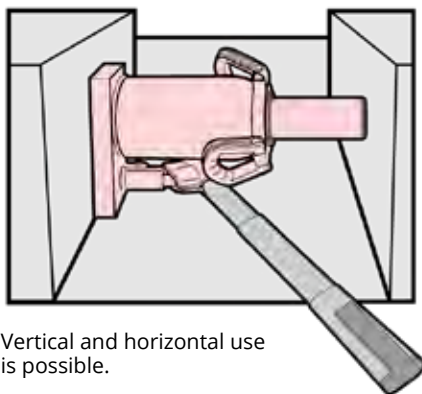

Vertical and horizontal use
is possible.

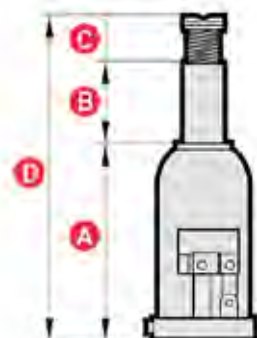

| Model | Weight (kg) | Capacity (t) | A | B | C | D |
|-------------|-------------|--------------|-----|-----|----|-----|
| BR3 | 3.7 | 3 | 168 | 105 | 65 | 338 |
| BR5 | 4.5 | 5 | 212 | 150 | 75 | 437 |
| BR10 | 6.4 | 10 | 219 | 150 | 75 | 444 |

Measurements in mm.



AVAILABLE
IN GREY

Bottle jacks 15 – 100 t BR and MGD

- Heavy duty hydraulic jacks designed and tested for high performance work.
- Models from 20t upwards are equipped with a rotating carrying handle and an integrated support to place the telescopic handle and facilitate storage.
- Equipped with a unique rotating pump system which can be operated in any position.
- All models have an extension screw for a fast approach to the load.
- The welded base and body of the bottle provides greater stability and safety.
- Zinc-plated telescopic handle easy to store. Length suitable for moderate pumping effort.



Safety overload valve.



Hydraulic stroke limiter.



Extension screw
for longer travel

BR30



Rotating transport handle,
with lever housing space

BR50



Rotary pump socket.

MGD-100

The **MGD-100** model is equipped with pressure gauge and two pumps (approach and operation).



| Model | Weight (kg) | Capacity (t) | Carrying handle | A | B | C | D |
|----------------|-------------|--------------|-----------------|-----|-----|----|-----|
| BR15 | 8.8 | 15 | - | 228 | 150 | 75 | 453 |
| BR20 | 10.6 | 20 | • | 234 | 150 | 75 | 459 |
| BR30 | 14.5 | 30 | • | 242 | 150 | 75 | 467 |
| BR40 | 22.5 | 40 | • | 246 | 150 | - | 396 |
| BR50 | 27.0 | 50 | • | 260 | 140 | - | 400 |
| MGD-100 | 87.0 | 100 | • | 300 | 150 | - | 450 |

Measurements in mm.



Low profile bottle jacks BRS

- Designed for special applications, to access very small spaces which cannot be reached with a standard jack.
- Equipped with a unique rotating pump system accessible in any position.
- All models have an extension screw for fast load approach.



Safety overload valve.



Hydraulic stroke limiter.



| Model | Weight (kg) | Capacity (t) | A | B | C | D |
|--------------|-------------|--------------|-----|-----|----|-----|
| BRS10 | 5.0 | 10 | 131 | 62 | 30 | 223 |
| BRS20 | 9.5 | 20 | 190 | 105 | 55 | 350 |

Measurements in mm.



AVAILABLE
IN GREY

BRS10



AVAILABLE
IN GREY

BRT12



Telescopic bottle jacks BRT

Design that combines a low minimum height with a long lifting range thanks to its two telescopic pistons.

Equipped with a unique rotating pump system accessible in any position.



Safety overload valve.



Hydraulic stroke limiter.



| Model | Weight (kg) | Capacity (t) | A | B | C | D |
|--------------|-------------|--------------|-----|-----|---|-----|
| BRT12 | 15.4 | 12 | 245 | 326 | - | 571 |
| BRT20 | 22.0 | 20 | 180 | 205 | - | 385 |

Measurements in mm.

Toe jack MGL

- Designed for the safe lifting of very low and difficult to handle elements.
- Ideal for forklift maintenance, lifting of heavy machinery.
- The lifting claw is removable and adjustable in two positions.

Extra low lifting
claw (25 mm)

MGL10

BL10 + BR10 = MGL10
CHASSIS BOTTLE PRODUCT

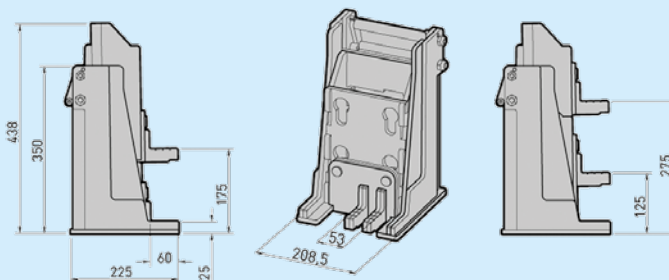

BL10









AVAILABLE
IN GREY

Parallel legs folding cranes CRP

The CRP models are strong and robust cranes with parallel legs designed to house a pallet under the arm that allows placing the load on the pallet safely.

Equipped with two handles and a new tilting system consisting of 4 wheels at the back and 2 at the front, they are very easy to handle and move, both with and without load.

-  Operation by "dead man's" principle.
-  Hydraulic stroke limiter.
-  Safety overload valve.
-  LCS lowering control system.



Swivel hydraulic unit for use in different positions. It incorporates a knob with an extremely precise lowering control.



Crane swings on swivel wheels. Front wheels do not touch the ground when crane is not loaded. Maximum manoeuvrability. **Patented.**

CRP20

Plastic protections that prevent possible damage to vehicles and serve as a safety warning thanks to their excellent visibility.

The pedal makes it easier to manoeuvre the crane when it is empty. **Patented.**



Compact design is perfect for storage in small spaces. All models are equipped with polyamide wheels that facilitate manoeuvrability, do not damage the garage floor, do not rust and are very silent.

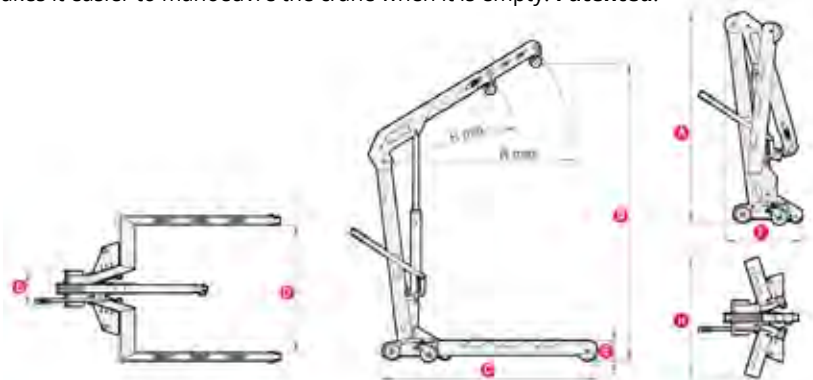

| Model | Weight (kg) | Capacity (kg) | A | B | C | D | E | R min. | R max. | F | G | H |
|-------|-------------|---------------|-------|-------|-------|-------|-----|--------|--------|-----|-----|-------|
| CRP10 | 99 | 1,000 | 1,580 | 2,200 | 1,480 | 870 | 122 | 960 | 1,300 | 620 | 300 | 865 |
| CRP20 | 150 | 2,000 | 1,740 | 2,460 | 1,800 | 1,070 | 170 | 1,200 | 1,610 | 740 | 300 | 1,050 |

Measurements in mm.



AVAILABLE
IN GREY

Standard folding cranes CRV

- Workshop crane that allows the removal and maintenance of a vehicle's engine so that the entire repair can be carried out in complete safety.
- **MEGA** CRV models are strong and robust cranes, specially designed for easy folding and unfolding. Equipped with two handles and a new tilting system with 4 wheels at the back and 2 at the front, very easy to handle and move, both with and without load.
- Compact design perfect for storing in small spaces.
- All models are equipped with polyamide wheels that facilitate manoeuvrability, do not damage the garage floor, do not rust and are very silent.



Operation by "dead man's" principle.



Hydraulic stroke limiter.



Safety overload valve.



LCS lowering control system.



Swivel hydraulic unit for use in different positions. It incorporates a knob with an extremely precise lowering control.

Tonnage indicator

Push button for automatic arm position change. **Patented.**

Crane swings on swivel wheels. Front wheels do not touch the ground when crane is not loaded. Maximum manoeuvrability. **Patented.**

Greater robustness, stability and accessibility thanks to the double legs in the **CRV10** and **CRV20** models.

**NEW
PRODUCT**

CRV5

CRV20

Compact design is perfect for storage in small spaces.

All models are equipped with polyamide wheels that facilitate manoeuvrability, do not damage the garage floor, do not rust and are very silent.

| Model | Weight (kg) | Capacity (kg) | A | B | C | D | E | R min. | R max. | F | G | H |
|--------------|-------------|---------------|-------|-------|-------|-------|-----|--------|--------|-----|-----|-----|
| CRV5 | 81 | 550 | 1,450 | 2,180 | 1,510 | 825 | 112 | 900 | 1,300 | 440 | 410 | 510 |
| CRV10 | 85 | 1,000 | 1,580 | 2,200 | 1,525 | 970 | 112 | 960 | 1,300 | 615 | 300 | 615 |
| CRV20 | 143 | 2,000 | 1,740 | 2,460 | 1,830 | 1,100 | 170 | 1,200 | 1,610 | 680 | 300 | 725 |

Measurements in mm.



AVAILABLE
IN GREY

High performance crane CRM

The CRM model crane has a reinforced structure, very stable due to its width, making it suitable for safely and reliably operating heavy loads.

The design of the extendable and folding arm, allows maximum operator approach.



Operation by "dead man's" principle.



Hydraulic stroke limiter.



Safety overload valve.



LCS lowering control system.



CRM30

Large polyamide wheels that facilitate manoeuvrability, do not damage the garage floor, do not rust and are very silent.



The 3t model, **CRM30**, is equipped with a two piston pump.

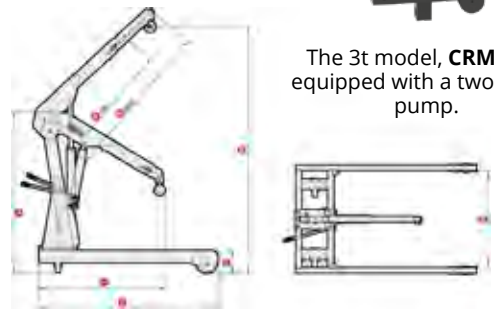

| Model | Weight (kg) | Capacity (kg) | A | B | C | D | E | R min. | R max. | F |
|--------------|-------------|---------------|-------|-------|-------|-------|-----|--------|--------|-------|
| CRM30 | 302 | 3,000 | 1,919 | 2,942 | 2,143 | 1,126 | 268 | 1,430 | 1,880 | 1,507 |

Measurements in mm.

Loading capacity

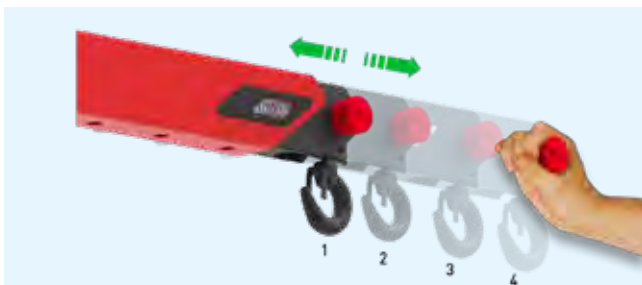

The extendable arm changes position with a simple touch of the bottom. Equipped with handle and positioning guiding window that shows the maximum working load. **Patented.**

| Position (kg) | 1 | 2 | 3 | 4 |
|--------------------|------------------|-------|-------|-------|
| Reference | Loading capacity | | | |
| CRV10/CRP10 | 1,000 | 900 | 800 | 700 |
| CRV20/CRP20 | 2,000 | 1,750 | 1,500 | 1,250 |
| CRM30 | 3,000 | 2,500 | 2,300 | 2,100 |

Measurements in mm.

Accessories



AB-300



Drum lifting clamp. For 200 litre steel drums. Only for closed drums with flange or removable top drums, provided the lid is properly closed. **Optional.**



A-5298

L = 1 m

Load leveller. **Optional.**



AVAILABLE
IN GREY

High lift or under platform transmission jacks TRS

- Designed to work in pits or underneath elevated vehicles.
- Lifting and lowering of the load using the foot pedal allow hands to be free.
- Easy manoeuvrability thanks to four swivel castors and a very stable base.
- All controls are pedal-operated.



Operation by "dead man's" principle.



Hydraulic stroke limiter.



Safety overload valve.



LCS lowering control system.



Unique jack with two pedal controls.
Maximum stability, comfort and functionality.



Protective foam block included. **Patented.**

Accessories



PF350

Adjustable platform with chains.
Capacity : 350 kg.
Optional.



TRS750

Handle with screws tray, adjustable to different positions.

Rubber protections that prevent possible damage to vehicles or crane legs.
Great safety warning to avoid knocks or tripping thanks to their good visibility.

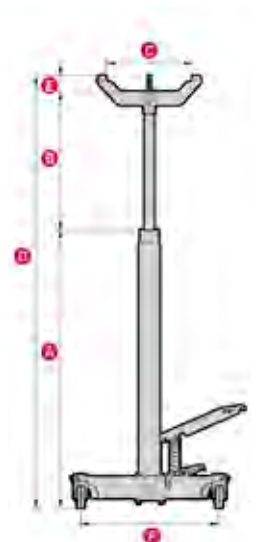

| Model | Weight (kg) | Capacity (Kg) | A | B | C | D | E | F |
|----------------|-------------|---------------|-------|-----|-----|-------|----|-----|
| TRS300 | 26 | 300 | 1,200 | 850 | 315 | 2,050 | 60 | 720 |
| TRS750 | 28 | 750 | 1,110 | 820 | 315 | 1,930 | 60 | 720 |
| TRS1200 | 34 | 1,200 | 1,110 | 815 | 315 | 1,925 | 60 | 720 |

Measurements in mm.



AVAILABLE
IN GREY

Premium pneumatic press with pedal PRP

- Sliding cylinder.
- High-speed pneumatic approach.
- Foot pedal for precision work.
- The most complete premium press on the market, equipped with all the accessories as standard.
- Its special design with the operation and discharge controls on the pedals, allows the operator to free his hands, facilitating his work in the fast and precise positioning of the element in the press.
- Larger chassis width for easier handling in the working area.



Piston with automatic return.



Hydraulic stroke limiter.



Safety overload valve.



Extendable screw for fast and precise approach.

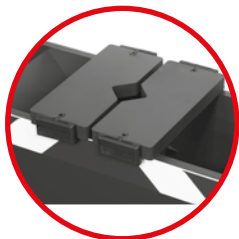

Reversible V blocks with extraction space with sliding guide for secure fastening. **Patented.**

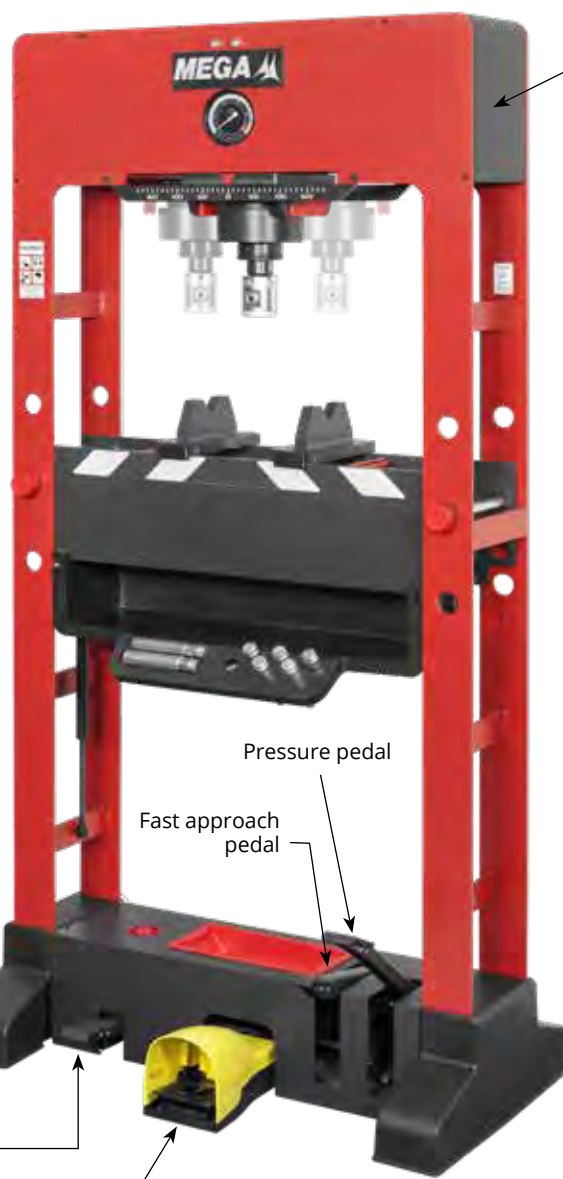

Easy access cover for maintenance



Extendable screw for a fast and precise approach to the working position.



Bottom tray designed to collect parts, oil, grease, dirt. It can also be placed on the central work table. **Patented.**

Legs with bolts for floor fixing

Release pedal

Pneumatic operation pedal

Pressure pedal

Fast approach pedal

PRP50

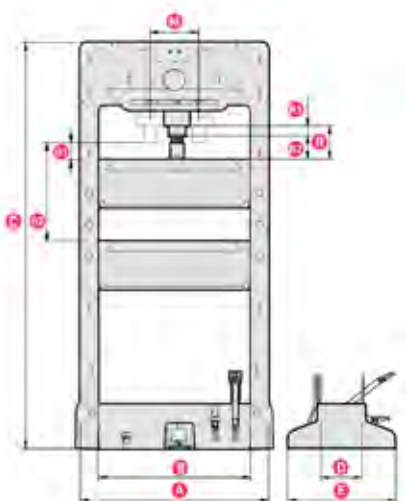

See optional accessories on page 32

| Model | Weight (kg) | Capacity (t) | A | B | C | D | E | G1 min. | G2 max. | R1 run | R2 spindle stroke | R total run | M lateral run |
|--------------|-------------|--------------|-----|-----|-------|-----|-----|---------|---------|--------|-------------------|-------------|---------------|
| PRP50 | 225 | 50 | 890 | 720 | 1,920 | 195 | 490 | 80 | 465 | 120 | 75 | 195 | 225 |

Measurements in mm.



AVAILABLE
IN GREY

Two-speed manual press PRD

- Sliding cylinder.
- Equipped with one lever for fast approach and another for precision work.
- Robust design with wider chassis for easier handling in the working area. Integrates all hydraulic elements within the chassis, protecting them and saving space in the workshop.



Piston with automatic return.



Hydraulic stroke limiter.



Safety overload valve.



Extendable screw for fast and precise approach.



Extendable screw for a fast and precise approach to the working position.

Winch to assist easy and quick positioning of the workbench



Set of punches.
Optional.

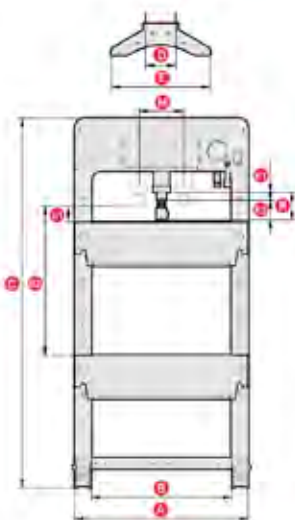

See optional accessories on page 32

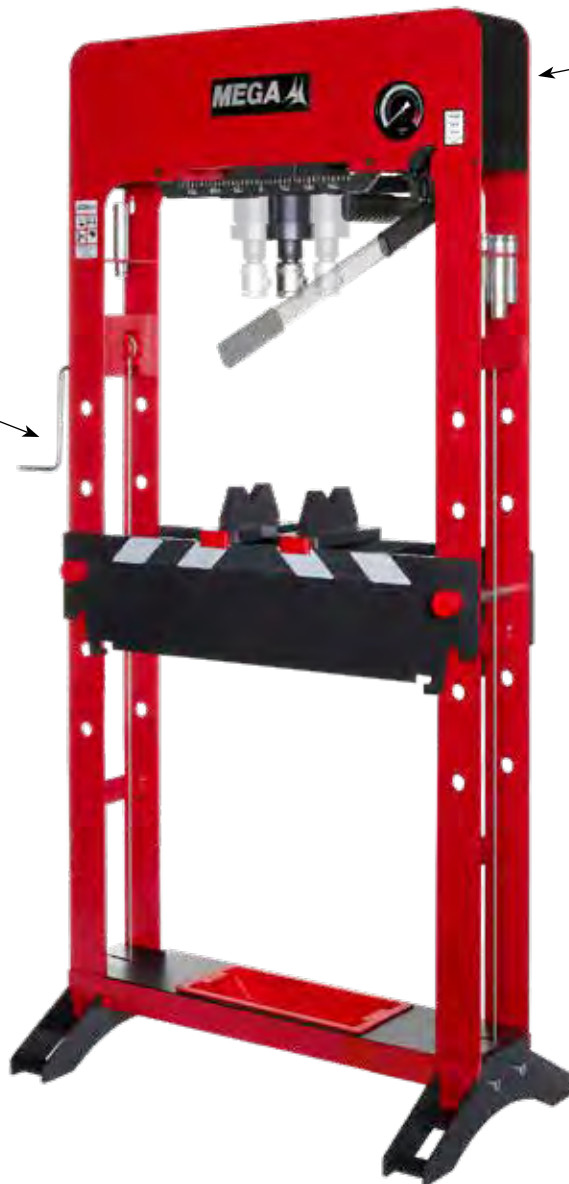

Easy access cover for maintenance



The manual model includes two pistons: approach and work.

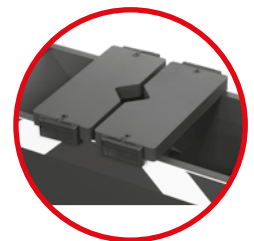

Reversible V blocks with extraction space with sliding guide for secure fastening.
Patented.



Bottom tray designed to collect parts, oil, grease, dirt. It can also be placed on the central work table. **Patented.**

| Model | Weight (kg) | Capacity (t) | A | B | C | D | E | G1 min. | G2 max. | R1 run | R2 spindle stroke | R total run | M lateral run |
|--------------|-------------|--------------|-----|-----|-------|-----|-----|---------|---------|--------|-------------------|-------------|---------------|
| PRD30 | 147 | 30 | 890 | 720 | 1,900 | 150 | 490 | 84 | 770 | 120 | 75 | 195 | 212 |
| PRD50 | 191 | 50 | 890 | 720 | 1,900 | 150 | 490 | 84 | 770 | 120 | 75 | 195 | 189 |

Measurements in mm.



AVAILABLE
IN GREY

Pneumatic and manual press PRD-NF

- Sliding cylinder.
- High-speed pneumatic approach.
- Lever for precision work.
- Robust design with wider chassis for easier handling in the working area. Integrates all hydraulic elements within the chassis, protecting them and saving space in the workshop.



Piston with automatic return.



Hydraulic stroke limiter.



Safety overload valve.



Extendable screw for fast and precise approach.

Easy access cover for maintenance

Winch to assist easy and quick positioning of the workbench



Set of punches.
Optional.



Bottom tray designed to collect parts, oil, grease, dirt. It can also be placed on the central work table. **Patented.**



Extendable screw for a fast and precise approach to the working position.

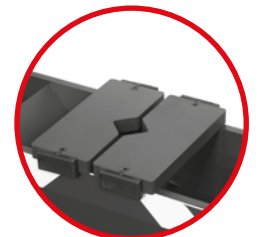

Reversible V blocks with extraction space with sliding guide for secure fastening. **Patented.**

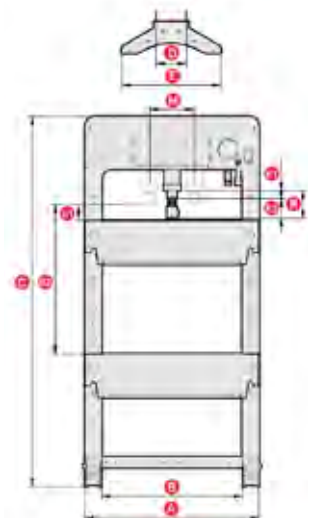

See optional accessories on page 32

| Model | Weight (kg) | Capacity (t) | A | B | C | D | E | G1 min. | G2 max. | R1 run | R2 spindle stroke | R total run | M lateral run |
|----------------|-------------|--------------|-----|-----|-------|-----|-----|---------|---------|--------|-------------------|-------------|---------------|
| PRD30NF | 147 | 30 | 890 | 720 | 1,900 | 150 | 490 | 84 | 770 | 120 | 75 | 195 | 212 |
| PRD50NF | 191 | 50 | 890 | 720 | 1,900 | 150 | 490 | 84 | 770 | 120 | 75 | 195 | 189 |

Measurements in mm.



AVAILABLE
IN GREY

Electrohydraulic press PRD-E

- Sliding cylinder.
- Double-acting electro-hydraulic pump 400V three-phase 50/60 Hz (optional 230V single-phase pump).
- Robust design with wider chassis for easier handling in the working area. Integrates all hydraulic elements within the chassis, protecting them and saving space in the workshop.



Piston with automatic return.



Hydraulic stroke limiter.



Safety overload valve.



Extendable screw for fast and precise approach.

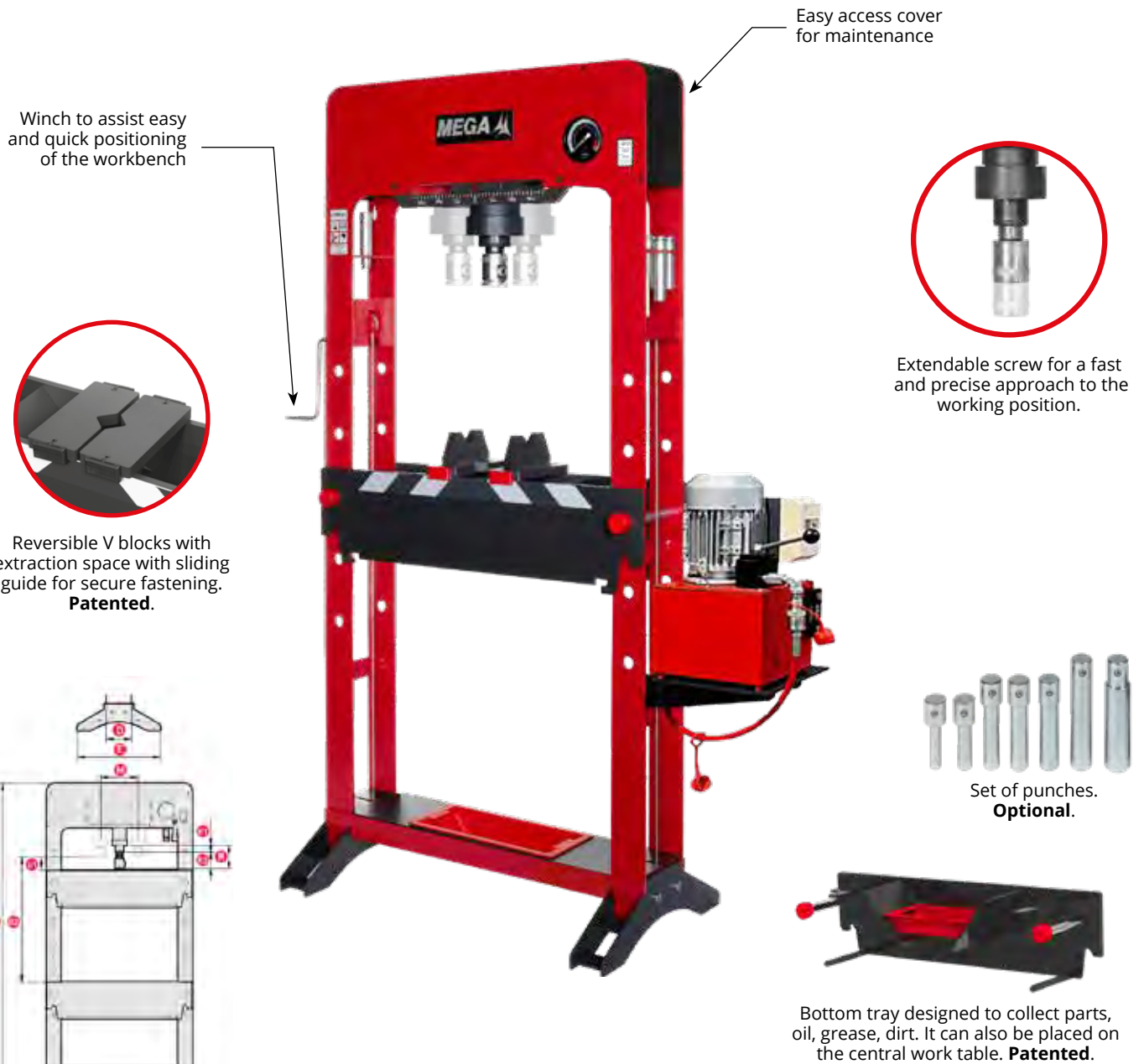

See optional accessories on page 32

| Model | Weight (kg) | Capacity (t) | A | B | C | D | E | G1 min. | G2 max. | R1 run | R2 spindle stroke | R total run | M lateral run |
|--------|-------------|--------------|-----|-----|-------|-----|-----|---------|---------|--------|-------------------|-------------|---------------|
| PRD50E | 232 | 50 | 890 | 720 | 1,900 | 150 | 490 | 84 | 770 | 120 | 75 | 195 | 189 |

Measurements in mm.



AVAILABLE
IN GREY

Manual compact press with two speeds PRC

- Equipped with one lever for fast approach and another for precision work.
- Functional and compact design, ideal for workshops and garages with limited space.
- Hydraulic press equipped with a piston that allows more working space.

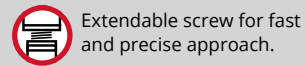
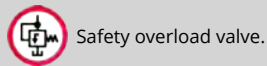
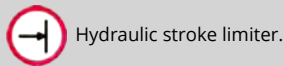
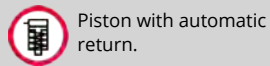

Extendable screw for a fast and precise approach to the working position.



The manual model includes two levers: approach and operation.



Set of punches.
Optional.

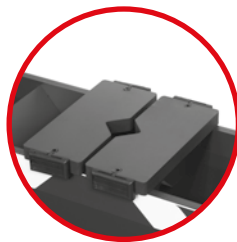

Reversible V blocks with extraction space with sliding guide for secure fastening.
Patented.

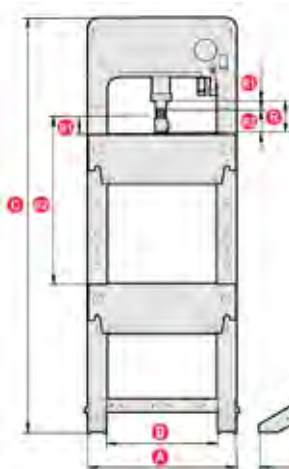

Bottom tray designed to collect parts, oil, grease, dirt. It can also be placed on the central work table. **Patented.**



See optional accessories on page 32

| Model | Weight (kg) | Capacity (t) | A | B | C | D | E | G1 min. | G2 max. | R1 run | R2 spindle stroke | R total run |
|--------------|-------------|--------------|-----|-----|-------|-----|-----|---------|---------|--------|-------------------|-------------|
| PRC30 | 112 | 30 | 670 | 530 | 1,850 | 132 | 488 | 17 | 854 | 120 | 75 | 195 |
| PRC50 | 145 | 50 | 670 | 530 | 1,850 | 132 | 488 | 66 | 766 | 120 | 75 | 195 |

Measurements in mm.



AVAILABLE
IN GREY

Compact pneumatic and manual press PRC-NF

- High-speed pneumatic approach.
- Lever for precision work.
- Functional and compact design, ideal for workshops and garages with limited space.
- Hydraulic press equipped with a piston that allows more working space.



Piston with automatic return.



Hydraulic stroke limiter.



Safety overload valve.



Extendable screw for fast and precise approach.



Extendable screw for a fast and precise approach to the working position.



Set of punches.
Optional.



Bottom tray designed to collect parts, oil, grease, dirt. It can also be placed on the central work table. **Patented.**



Easy access cover for maintenance

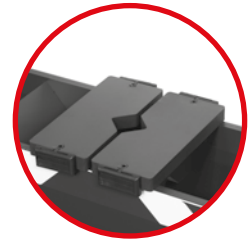

Reversible V blocks with extraction space with sliding guide for secure fastening. **Patented.**

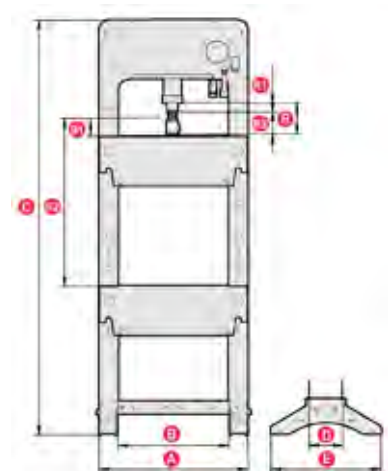

See optional accessories on page 32

| Model | Weight (kg) | Capacity (t) | A | B | C | D | E | G1 min. | G2 max. | R1 run | R2 spindle stroke | R total run |
|----------------|-------------|--------------|-----|-----|-------|-----|-----|---------|---------|--------|-------------------|-------------|
| PRC30NF | 112 | 30 | 670 | 530 | 1.850 | 132 | 488 | 17 | 854 | 120 | 75 | 195 |
| PRC50NF | 145 | 50 | 670 | 530 | 1.850 | 132 | 488 | 66 | 766 | 120 | 75 | 195 |

Measurements in mm.



AVAILABLE
IN **GREY**

Compact manual press **PRB**

- The compact and reinforced structure guarantees maximum robustness and resistance to stress. Specially designed to save as much space as possible in the workshop.
- Spring return system cylinder.



Hydraulic stroke limiter.



Safety overload valve.



Extendable screw for fast and precise approach.

Easy access cover for maintenance



Extendable screw for a fast and precise approach to the working position.



Set of punches.
Optional.

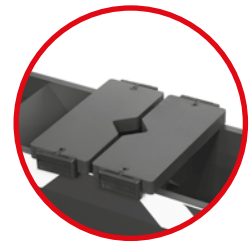

Reversible V blocks with extraction space with sliding guide for secure fastening.
Patented.



Bottom tray designed to collect parts, oil, grease, dirt. It can also be placed on the central work table. **Patented.**

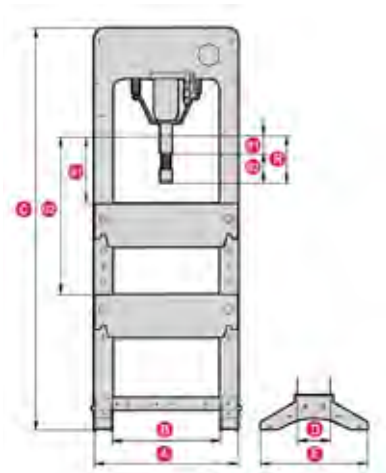

See optional accessories on page 32

| Model | Weight (kg) | Capacity (t) | A | B | C | D | E | G1 min. | G2 max. | R1 run | R2 spindle stroke | R total run |
|--------------|-------------|--------------|-----|-----|-------|-----|-----|---------|---------|--------|-------------------|-------------|
| PRB30 | 104 | 30 | 670 | 530 | 1.850 | 132 | 488 | 53 | 740 | 150 | 75 | 225 |

Measurements in mm.



AVAILABLE
IN GREY

Large tonnage manual press K100

- Double-acting hand pump.
- Dual-speed hand pump: 1st speed for fast approach and 2nd speed for a powerful and efficient work.
- Professional use press with double-acting cylinder, especially recommended for garages, repair shops and industrial maintenance.
- Robust construction designed for precise operation when extracting, bending, straightening, pressing, etc.
- Solid structure with a front width of 1200mm and a workbench easily adjustable with a winch that can be set at 5 different heights.
- Included set of 2 V-blocks with sliding guide and extraction space.



Hydraulic stroke limiter.



Safety overload valve.



Extendable screw for fast and precise approach.



See optional accessories on page 32

| Model | Weight (kg) | Capacity (t) | A | B | C | D | E | G1 min. | G2 max. | R total run |
|-------------|-------------|--------------|-------|-----|-------|-----|-----|---------|---------|-------------|
| K100 | 620 | 100 | 1,200 | 975 | 2,050 | 260 | 715 | 115 | 915 | 250 |

Measurements in mm.



AVAILABLE
IN GREY

Large tonnage electrohydraulic press K100E

- Double-acting electro-hydraulic pump 400V three-phase 50/60 Hz (optional 230V single-phase pump).
- Professional use press with double-acting cylinder, especially recommended for garages, repair shops and industrial maintenance.
- Robust construction designed for precise operation when extracting, bending, straightening, pressing, etc.
- Solid structure with a front width of 1200mm and a workbench easily adjustable with a winch that can be set at 5 different heights.
- Included set of 2 V-blocks with sliding guide and extraction space.



Hydraulic stroke limiter.



Safety overload valve.



Extendable screw for fast and precise approach.



Winch to assist easy and quick positioning of the workbench

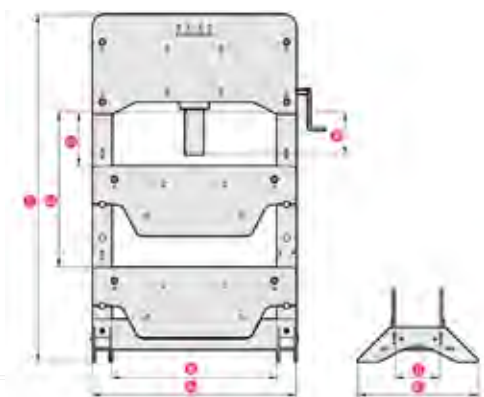

See optional accessories on page 32

| Model | Weight (kg) | Capacity (t) | A | B | C | D | E | G1 min. | G2 max. | R total run |
|--------------|-------------|--------------|-------|-----|-------|-----|-----|---------|---------|-------------|
| K100E | 620 | 100 | 1,200 | 975 | 2,050 | 260 | 715 | 115 | 915 | 250 |

Measurements in mm.



AVAILABLE
IN GREY

Large tonnage pneumatic press K100N

- 700 bar double-acting pneumatic pump.
- Professional use press with double-acting cylinder, especially recommended for garages, repair shops and industrial maintenance.
- Robust construction designed for precise operation when extracting, bending, straightening, pressing, etc.
- Solid structure with a front width of 1200mm and a workbench easily adjustable with a winch that can be set at 5 different heights.
- Included set of 2 V-blocks with sliding guide and extraction space.



Hydraulic stroke limiter.



Safety overload valve.



Extendable screw for fast and precise approach.

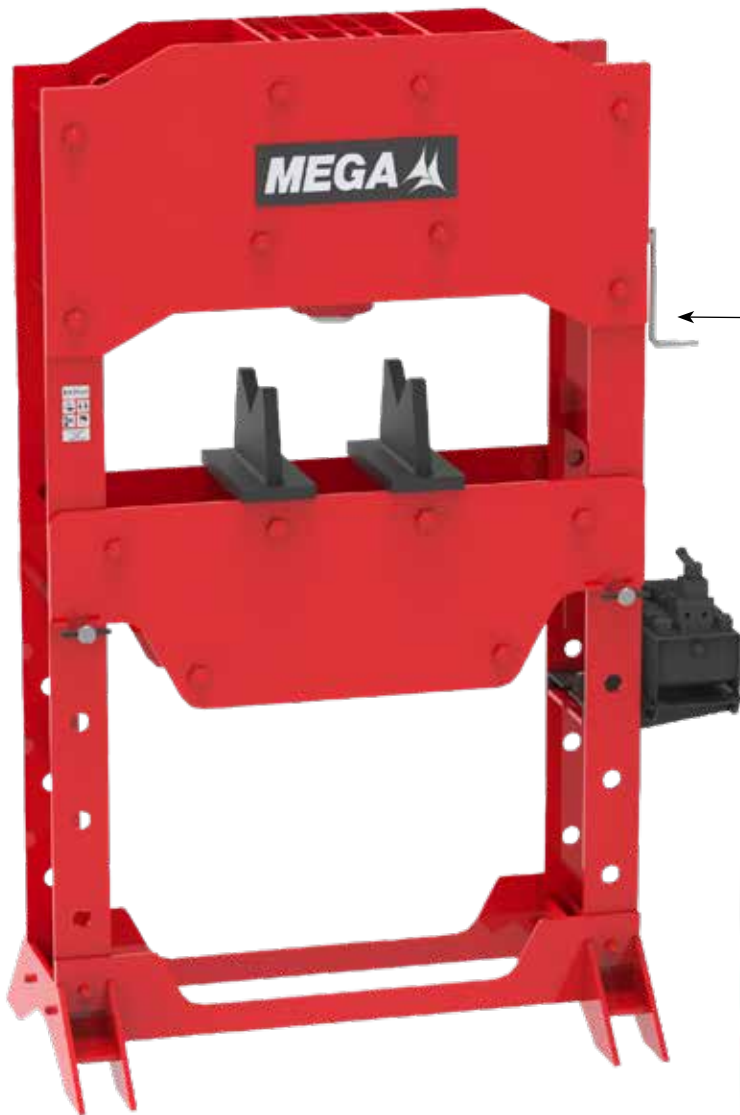

**NEW
PRODUCT**

Winch to assist easy and quick positioning of the workbench

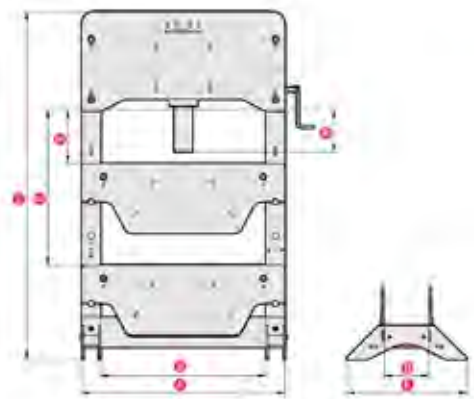

See optional accessories on page 32

| Model | Weight (kg) | Capacity (t) | A | B | C | D | E | G1 min. | G2 max. | R total run |
|--------------|-------------|--------------|-------|-----|-------|-----|-----|---------|---------|-------------|
| K100N | 620 | 100 | 1,200 | 975 | 2,050 | 260 | 715 | 115 | 915 | 250 |

Measurements in mm.



Desktop press PRS



AVAILABLE
IN GREY

- Welded robust monoblock chassis presses, specially designed to be used on tables and workbenches.
- Ultra-light for easy transport.



Piston with automatic return.



Hydraulic stroke limiter.



Safety overload valve.



Extendable screw for fast and precise approach.

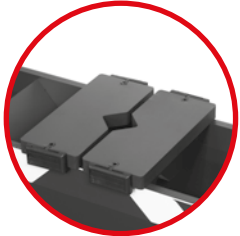

Reversible V blocks with extraction space with sliding guide for secure fastening. **Patented.**



Extendable screw for a fast and precise approach to the working position.



PRS15

Easy access cover for maintenance



Bottom tray designed to collect parts, oil, grease, dirt. It can also be placed on the central work table. **Patented.**

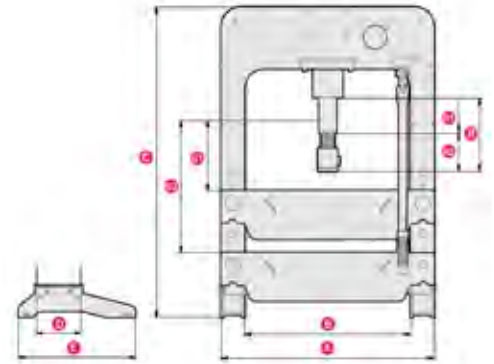

| Model | Weight (kg) | Capacity (t) | A | B | C | D | E | G1 min. | G2 max. | R1 run | R2 spindle stroke | R total run |
|--------------|-------------|--------------|-----|-----|-----|-----|-----|---------|---------|--------|-------------------|-------------|
| PRS15 | 48 | 15 | 550 | 430 | 800 | 132 | 350 | 45 | 338 | 95 | 75 | 170 |

Measurements in mm.

Press accessories

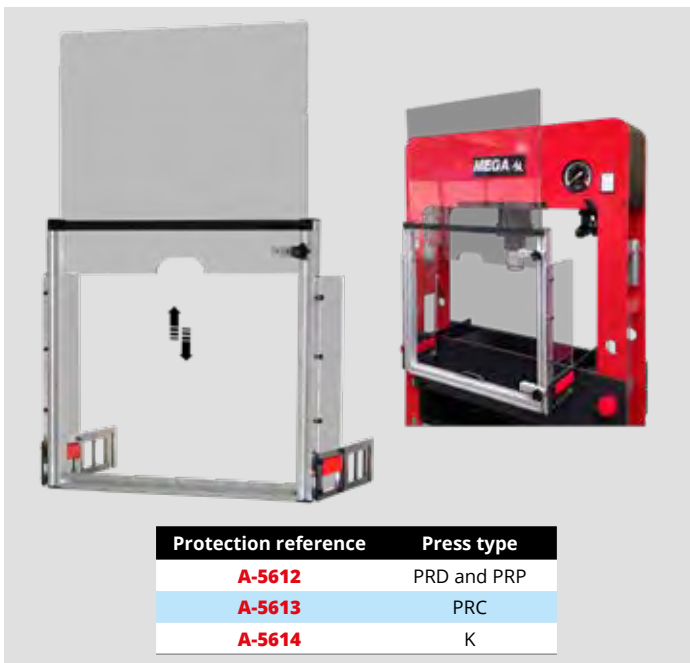

| Protection reference | Press type |
|----------------------|-------------|
| A-5612 | PRD and PRP |
| A-5613 | PRC |
| A-5614 | K |

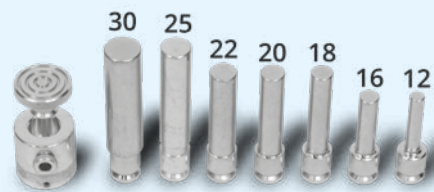

Available for all models.

A-5600: Set of punches for 30 and 50 t presses. **Optional.**

A-5601: Set of punches for 15 t presses. **Optional.**

* As the cylinders develop more force than the accessories, the punches should never exceed half their nominal force.



Available only for model PRD (ref. A-5609).

A-5609: Optional punches tray.



Lifting tables ME

All models have polyamide wheels for better manoeuvrability, do not damage the garage floor, do not rust and are quiet when operated.

The table can be locked at different heights with safety bolts.



AVAILABLE
IN GREY



Operation by "dead man's" principle.



Hydraulic stroke limiter.



Safety overload valve.



LCS lowering control system.

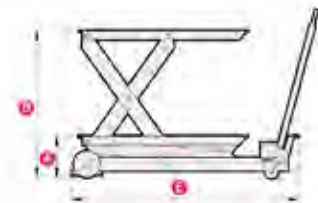

The wheels are equipped with brakes and foot protections.



YouTube



ME-1500

| Model | Weight (kg) | Capacity (kg) | A | B | C | D | E | F |
|----------------|-------------|---------------|-----|-----|-------|-----|-------|-----|
| ME-1500 | 135 | 1,500 | 210 | 880 | 1,020 | 500 | 1,380 | 690 |
| ME-2500 | 187 | 2,500 | 300 | 880 | 1,060 | 540 | 1,440 | 795 |

Measurements in mm.

Pneumatic table for motorcycles PTM

- Unique in the market for its high lifting speed (3 to 8 seconds).
- A safety device allows the table to be locked at different heights and prevents any unexpected descents.
- Manual control of the descent speed.
- Supplied with chain for fixing the front wheel.
- Essential for convenient repair and maintenance of motorbikes.



DISPONIBLE
EN GRIS



Operation by "dead man's" principle.



Hydraulic stroke limiter.



Safety overload valve.



LCS lowering control system.

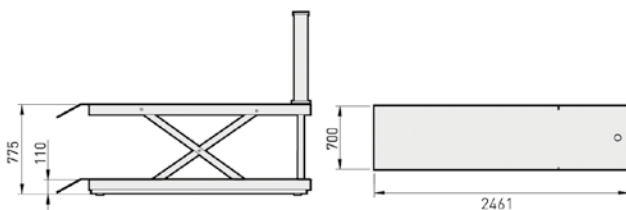

PTM-2

| Model | Weight (kg) | Capacity (kg) | Required air pressure | Required air flow |
|--------------|-------------|---------------|-------------------------|----------------------|
| PTM-2 | 161.5 | 450 | 7-10 bar / 100-145 psi. | 270 l/min / 9.5 cfm. |

Measurements in mm.



AVAILABLE
IN GREY

Wheel dolly SCR

- Manual support handle to reduce the lifting effort when working at maximum capacity is required.
- Chain for safe handling of the wheels.
- Special design for removal of twin and large size wheels.
- Each arm has two rollers to allow the truck's twin wheels to turn independently.
- Lifting arms adjustable in five positions.



Operation by "dead man's" principle.



Hydraulic stroke limiter.



Safety overload valve.



LCS lowering control system.



SCR700



Lifting and lowering on the pedal keeps your hands free.



YouTube

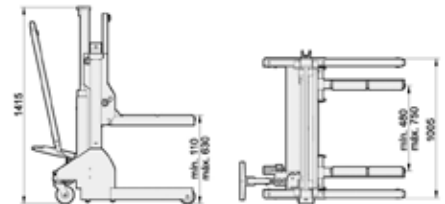

| Model | Weight (kg) | Capacity (kg) | Width between rollers | Min. roller height | Max. elevation |
|---------------|-------------|---------------|-----------------------|--------------------|----------------|
| SCR700 | 152 | 700 | 480-750 | 110 | 630 |

Measurements in mm.





Transmission jack GCB

Suitable for the assembly of gearboxes, transmissions, engines. It has chains for the safe movement of the load.

Equipped with detachable pump, which allows the jack to be used in any position.



AVAILABLE
IN GREY



Safety overload valve.



Hydraulic stroke limiter.

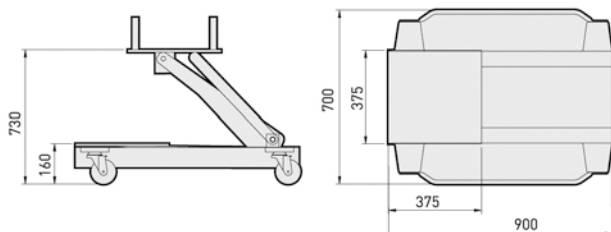

| Model | Weight (kg) | Capacity (kg) |
|--------------|-------------|---------------|
| GCB-2 | 86 | 1,000 |

Measurements in mm.



YouTube

GCB-2



Body repair kits GC

- The most complete body repair kit due to its number of accessories, more safer and sturdier thanks to the threaded connections which allow pulling operations, compared with other more extensive but less reliable connection systems in the market which only allow pushing operations.
- Indispensable for jobs such a body repairs, rescue and roadside service or any other pushing, pulling, separating or lifting applications that require hydraulic force.
- The maximum capacity of the **SH-1** expansion cylinder is 1t and the maximum working load of the chain is 1t.
- Safety overload valve.
- Hydraulic stroke limiter.
- Piston return by internal spring.

IMPORTANT: As the cylinders have a greater capacity than the accessories, especially the chain, the separating components, the fixing clamps, tube extension, etc., **they should never exceed half of the rated capacity.**



| Capacity (t) | 10 | 20 |
|--------------|---------------------|---------------------|
| 1 | BM-04 | BM-04 |
| 2 | CC-10-B | CC-20-B |
| 3 | GC-10/2272 | A-5167 |
| 4 | A-5541 | A-5541 |
| 5 | A-5033 / Ø 42 L 700 | A-5233 / Ø 60 L 700 |
| 6 | A-5034 / Ø 42 L 480 | A-5234 / Ø 60 L 460 |
| 7 | A-5035 / Ø 42 L 230 | A-5235 / Ø 60 L 255 |
| 8 | A-5048 | - |
| 9 | A-5042 | A-5242 |
| 10 | A-5038 | A-5238 |
| 11 | A-5053 | - |
| 12 | A-5054 | - |
| 13 | A-5055 | A-5284* |
| Model | GC-10 | GC-20 |

| Capacity (t) | 10 | 20 |
|--------------------|---------------------|--------------|
| 14 | A-5050 | A-5280* |
| 15 | A-5039 | A-5239 |
| 16 | A-5036 / Ø 42 L 130 | - |
| 17 | A-5049 | - |
| 18 | SH-1 | - |
| 19 | A-5043 | - |
| 20 | A-5086 | - |
| 21 | A-5057 | - |
| 22 | A-5058 | - |
| 23 | A-5056 | - |
| 24 | A-5051 | A-5252* |
| 25 | A-5052 | - |
| Weight (kg) | 41.5 | 45 |
| Model | GC-10 | GC-20 |

* These components have a different design from the one shown in the photo.



AVAILABLE
IN GREY

Body aligning set EHA

Designed to carry out precise repair of the most badly-damaged cars.

The possibility of rotating the arm increases its versatility by allowing to pull from different angles.

As an option, it can be equipped with the **NS-2** pneumatic pump, with foot pedal, which allows the operator to have his hands free.

IMPORTANT: The maximum working load of the chain is 1.4t.



Hydraulic stroke limiter.



Safety overload valve.



Pistón con retorno automático.



New Sized Packaging
for easier transport

Dimensions: **231 x 55 x 37 cm.**



EHA-10

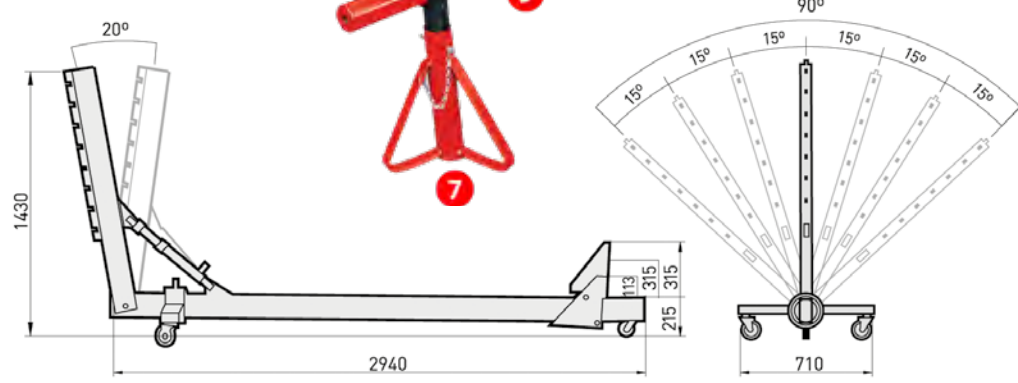

| Model | Weight (kg) | Capacity (t) | 1 | 2 | 3 | 4 | 5 | 6 | 7 | 8 | 9 | 10 | 11 | 12 |
|---------------|-------------|--------------|-------|---------|--------|--------|--------|--------|------|--------|--------|--------|--------|--------|
| EHA-10 | 178.5 | 10 | BM-04 | CC-10-B | A-5541 | A-5096 | A-5095 | A-5094 | S-21 | A-5087 | A-1512 | A-1513 | A-5088 | A-5089 |

Pneumatic Jack TL2

Body shops, tire service, mechanical workshops, etc.

Allows lifting half of the vehicle from the front or rear to work at the correct height or change tires.



Operation by "dead man's" principle.



Hydraulic stroke limiter.



Safety overload valve.



LCS lowering control system.



YouTube



| Model | Weight (kg) | Capacity (kg) | A | B | C |
|------------|-------------|---------------|-----|-------|-----|
| TL2 | 110 | 2,500 | 550 | 1,382 | 626 |

Measurements in mm.



Single-acting pedal-operated oil-pneumatic pump NS2

Single-acting air-hydraulic pedal pump

Air driven pumps for operation where electric power is not available or dangerous.

press down on the back section of pedal for operation. Descent or pressure release is effected by pressing down on the front section.

With safety relief valve, factory rated at the maximum working pressure.



| Model | Weight (kg) | Effective oil volume | Working pressure | Air pressure | Noise level |
|------------|-------------|-----------------------|------------------|--------------|-------------|
| NS2 | 6.5 | 2,100 cm ³ | 700 bar | 2.8-10 bar | 75 dBA |



Hydraulic pipe benders DR

- Bending work can be carried out without physical effort thanks to the high force of the hydraulic unit.
- Fitted with indelibly marked retractable bending frame to facilitate the positioning of the bending supports and pipe.
- New "V" shape frame design with 90° angle reference, which reduces the hydraulic stroke, and the bending time.
- For plumbing pipes, DIN 2440 and DIN 2441.
- PThey can make angles of up to 180°.
- SThey are supplied with a tripod and a swiveling telescopic lever.
- **DR2:** supplied in a plastic box.
- **DR3:** supplied in a wooden box.



Hydraulic stroke limiter.



Safety overload valve.



Pistón con retorno automático.



The weight distribution allows easy.

Comfortable transport.



Swiveling telescopic handle.



DR3



The following sets are supplied:

DR2: 3/8" - 1/2" - 3/4" - 1" - 1.1/4" - 1.1/2" - 2".

DR3: 3/8" - 1/2" - 3/4" - 1" - 1.1/4" - 1.1/2" - 2" - 2.1/2" - 3".

| Model | Weight (kg) | Tubos hasta |
|------------|-------------|-------------|
| DR2 | 43.0 | 2" |
| DR3 | 86.5 | 3" |

Axle stands C & S

- Axle stands to secure loads as an essential safety measure.
- High stability and wide support feet to protect the workshop floor.
- Possibility to lock at different heights.



C6



C10

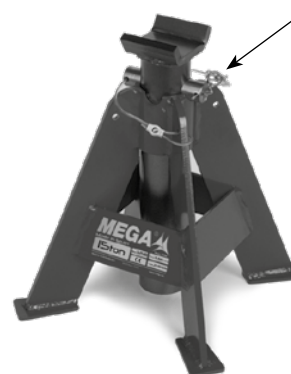

S15B

Pin attached to the base to prevent loss.

| Model | Weight (kg) | Capacity (t) | H min. | H max. | Posit. |
|-------------|-------------|--------------|--------|--------|--------|
| C6 | 6.0 | 6 | 360 | 520 | 5 |
| C10 | 10.5 | 10 | 375 | 550 | 5 |
| S15B | 9.3 | 15 | 340 | 532 | 4 |

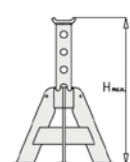
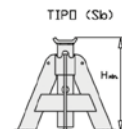
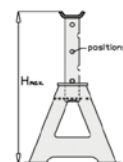
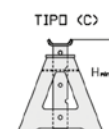

Measurements in mm.

Jack exhibitor

This display facilitates the combined and functional presentation of the most popular bottleand trolley jacks completely removable.

**A-5551L**

Index of references

| No. | DESCRIPTION | Pages |
|---------|-------------------------------|-------|
| A-5205 | EXTENDER | 13 |
| A-5206 | EXTENDER | 13 |
| A-5211 | EXTENDER | 13 |
| A-5212 | EXTENDER | 13 |
| A-5298 | LOAD BALANCER | 20 |
| A-5551L | COMBINED EXHIBITOR | 40 |
| A-5600 | SET OF PUNCHES | 32 |
| A-5601 | SET OF PUNCHES | 32 |
| A-5609 | LARGE BLACK TRAY | 32 |
| A-5612 | PROTECTION PRESS PRD-PRP | 32 |
| A-5613 | PROTECTION PRESS PRB-PRC | 32 |
| A-5614 | PROTECTION PRESS K | 32 |
| BL10 | TOE JACK FRAME | 17 |
| AB-300 | DRUM LIFTING CLAMP | 20 |
| A-PF350 | ADJUSTABLE PLATFORM | 6 - 7 |
| BR10 | BOTTLE JACK 10T | 15 |
| BR15 | BOTTLE JACK 15T | 15 |
| BR20 | AIR HYDRAULIC BOTTLE JACK 20T | 16 |
| BR3 | BOTTLE JACK 3T | 15 |
| BR30 | AIR HYDRAULIC BOTTLE JACK 30T | 16 |
| BR40 | BOTTLE JACK 40T | 16 |
| BR5 | BOTTLE JACK 5T | 15 |
| BR50 | BOTTLE JACK 50T | 16 |
| BRB20 | AIR HYDRAULIC BOTTLE JACK 20T | 14 |
| BRB30 | AIR HYDRAULIC BOTTLE JACK 30T | 14 |
| BRS10 | LOW PROFILE BOTTLE JACK 10T | 17 |
| BRS15 | LOW PROFILE BOTTLE JACK 15T | 16 |
| BRS20 | LOW PROFILE BOTTLE JACK 20T | 17 |
| BRT12 | LOW PROFILE BOTTLE JACK 12T | 17 |
| BRT20 | TELESCOPIC BOTTLE JACK 20T | 17 |
| C6 | AXLE STAND 6 T | 39 |
| C10 | AXLE STAND 10 T | 39 |
| CRM30 | HYDRAULIC CRANE 3000KG | 20 |
| CRP10 | HYDRAULIC CRANE P 1000KG | 18 |
| CRP20 | HYDRAULIC CRANE P 2000KG | 18 |
| CRV5 | HYDRAULIC CRANE P 550 KG | 19 |
| CRV10 | HYDRAULIC CRANE V 1000KG | 19 |
| CRV20 | HYDRAULIC CRANE V 2000KG | 19 |
| DR2 | PIPE BENDER 2" | 39 |
| DR3 | PIPE BENDER 3" | 39 |
| EHA-10 | BODY ALIGNING SET | 37 |
| GC-10 | BODY REPAIR KIT 10T | 36 |
| GC-20 | BODY REPAIR KIT 20T | 36 |
| GCB-2 | TRANSMISSION JACK | 35 |
| GT1.5H | TROLLEY JACK 1.5T | 6 |
| GT2 | TROLLEY JACK 2T | 6 |

| No. | DESCRIPTION | Pages |
|---------|-----------------------------------|-------|
| GT4 | TROLLEY JACK 4T | 8 |
| GT2S | TROLLEY JACK 2T SECURITY | 7 |
| GT2X | ULTRA-LOW PROFILE TROLLEY JACK | 7 |
| GT3 | TROLLEY JACK 3T | 8 |
| GT3S | TROLLEY JACK 3T | 8 |
| K100 | HYDRAULIC PRESS | 29 |
| K100E | ELECTRIC HYDRAULIC PRESS | 30 |
| k100N | PNEUMATIC PRESS | 31 |
| ME-1500 | LIFTING TABLE | 33 |
| ME-2500 | LIFTING TABLE | 33 |
| MGD-100 | BOTTLE JACK 100T | 16 |
| MGL10 | TOE JACK | 17 |
| N10-3 | AIR HYDRAULIC JACK | 11 |
| N15-2 | AIR HYDRAULIC JACK | 11 |
| N15-2B | AIR HYDRAULIC JACK | 11 |
| N15-4 | AIR HYDRAULIC JACK | 12 |
| N20-3 | AIR HYDRAULIC JACK | 12 |
| N25 | AIR HYDRAULIC JACK | 12 |
| NP15-2B | AIR HYDRAULIC JACK PORTAB. 15-30T | 13 |
| NS-2 | AIR PUMP | 38 |
| PF350 | TILTING PLATFORM | 21 |
| PRB30 | WORKSHOP COLUMN PRESS 30T | 28 |
| PRC30 | COMPACT PRESS W. CYLINDER 30T | 26 |
| PRC30NF | COMPACT AIR HYDRA. PRESS 30T | 27 |
| PRC50 | COMPACT PRESS W. CYLINDER 50T | 26 |
| PRC50NF | COMPACT AIR HYDRA. PRESS 50T | 27 |
| PRD30 | MOBILE CYL. PRESS 30T | 23 |
| PRD30NF | MOBILE CYL. AIR HYDR. PRESS 30T | 24 |
| PRD50 | MOBILE CYL. PRESS 50T | 23 |
| PRD50NF | MOBILE CYL. AIR HYDRA. PRESS 50T | 24 |
| PRD50E | MOBILE CYL. PRESS 50T | 25 |
| PRP50 | AIR HYDR. PREMIUM PRESS 50T | 22 |
| PRS15 | DESKTOP PRESS 15T | 32 |
| PTM-2 | PNEUMATIC PLATFORM. MOTORCYCLE | 33 |
| S15B | AXLE STAND S15B | 39 |
| SCR700 | WHEEL DOLLY 700KG KG | 34 |
| T10 | HEAVY DUTY TROLLEY JACK | 9 |
| T15 | HEAVY DUTY TROLLEY JACK | 10 |
| T20 | HEAVY DUTY TROLLEY JACK | 10 |
| T6 | HEAVY DUTY TROLLEY JACK 6T | 9 |
| TL2 | PNEUMATIC JACK 2.5T | 38 |
| TRS1200 | HIGH LIFT TRANSM. JACK 1200KG | 21 |
| TRS300 | HIGH LIFT TRANSM. JACK 300KG | 21 |
| TRS750 | HIGH LIFT TRANSM. JACK 750KG | 21 |

GENERAL CATALOGUE 2025



NEW MEGA XXI, S.L.

Polígono Industrial Eitua, 6
48240 BERRIZ (VIZCAYA) SPAIN
Tel.: + 34 94 622 50 90
Fax.: + 34 94 622 52 78 / export@mega.es

www.mega.es